

应用

- 倾斜检测
- 安全
- 屏幕方向

亮点

- 强去抖滤波器
- 卓越的性能，抑制虚假碰撞/倾斜
- 无需固件去抖
- 触发可调范围为 0.001 - 2 秒
- 超低功耗
- 10K 时被动成本约为 0.02 美元
- 适用于 SQ-SEN-3xx、5xx、6xx 和 8xx 系列传感器

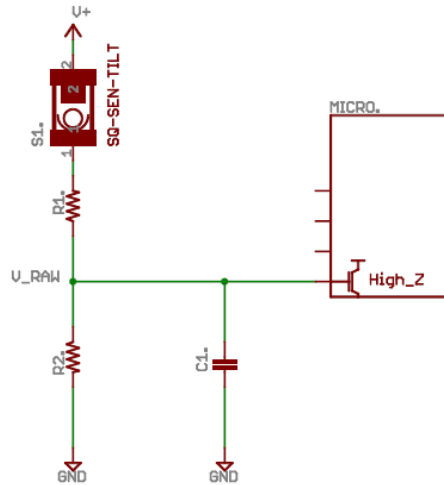

各种设置的输出示例
 以下几页提供了示例组件值。

行为

关闭事件 **0.001** 秒后触发。打开状态 **0.1** 秒后重置。非常有效地消除开关颤动。

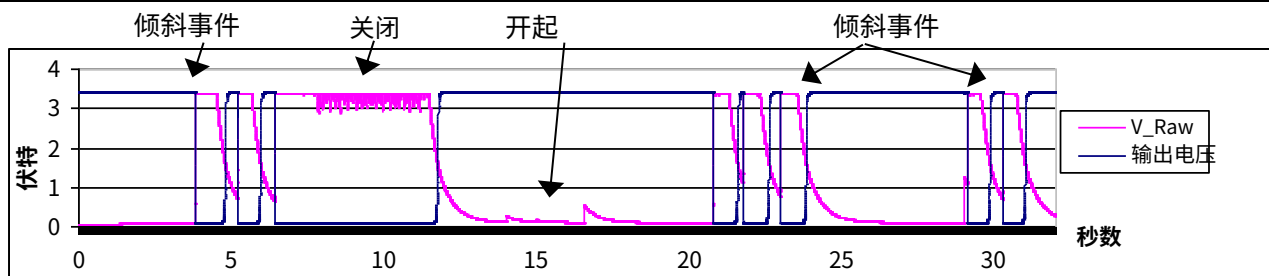

测试电路请参见下页注释。

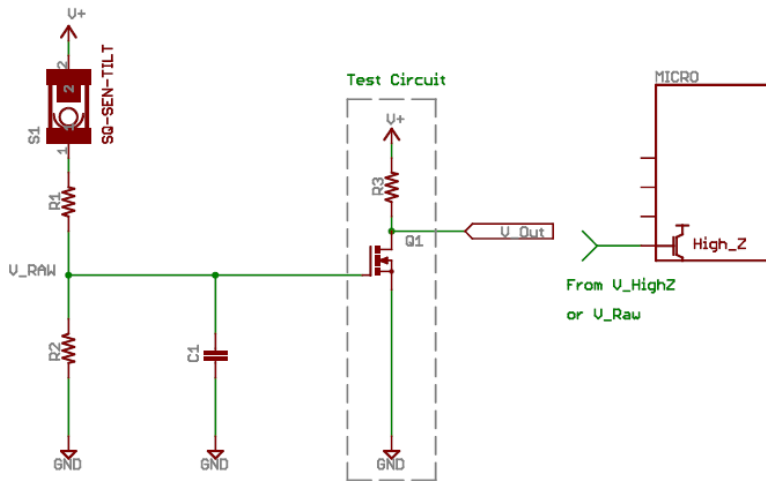

VALUES

电源电压 = 3.3V
 R1 = 1kΩ
 C1=0.01uF
 R2 = 2.5毫欧
 R3 = 1兆欧

组件和节点

R1	对 C1 充电并限制通过传感器的连续电流消耗。R1*C1 的 RC 时间常数控制传感器闭合后电路触发的速度。通过使用较小的 R1 值，可以实现对闭合信号的非常快速的响应。
R2	泄漏 C1 中存储的电荷并限制通过传感器的连续电流消耗。R2*C1 的 RC 时间常数控制传感器打开后电路恢复的速度。由于电路设计用于超低电流，因此需要较大的 R2 值（以限制连续电流消耗）。因此，R1 需要比 R2 小得多，因此 R1-R2 比率（分压器）允许出现全摆幅电压。如果 R1 太大，C1 上的电压将不会上升到足够高以触发 Q1 的基极。典型 FET 开启电压约为 1.7V。
C2	提供低通滤波。充电时间常数（当传感器关闭时）等于R1*C1。放电时间常数（当传感器打开时）等于R2*C1。低漏电电容器可以提高性能。
Q1	FET 提供超高阻抗输入，用于检测 C1 上累积的电压。当 C1 电压超过 FET 触发电压时，它将从开路变为闭合状态，反之亦然。低成本 N 沟道 FET 是合适的，例如 2N7000 或 2N7002。10K 时的成本约为 0.02 美元。
R3	由于电路设计为保证当传感器处于开路状态时 FET 将开路，因此 R3 的值可以相对较低。一个好的起点是对 R3 使用 100K 值。
MICRO	如果连接到微控制器，其输入引脚的阻抗需要非常高。引脚向上应该被禁用。如果输入阻抗不够高，无法实现高 Z/R1 比，则可以使用 FET 的 V_Out 驱动引脚（参见示例）。

BEHAVIOR

At rest, Q1 will have a guaranteed high (open) output and will produce a low going signal when the switch is closed. A key feature of this circuit is that it will always settle in a low current (open) when the sensor is at reset in its open position. If a normally low output is desired, then R3 can be moved to the emitter side of the FET.

NOTES

The Test Circuit above should be use to verify correct functionality and sensitivity. By measuring V_Out with an oscilloscope, an intuitive understanding of the circuit's behavior can be gained.

Measuring V_Raw with a standard oscilloscope or voltage meter **WILL DRAMATICALLY ALTER** the behavior of the circuit. Typical oscilloscopes have input impedance from 1M to 10M and this will load the high impedance node causing severe voltage droop. This is why the Test Circuit shown above is recommend for prototyping.

In many applications, connecting the output of the FET (V_Out) to the host microcontroller's input pin provides improved performance when compared to using V_Raw.

NON-MICROCONTROLLER APPLICATIONS

Applications that do not make use of a microcontroller can also be constructed from the above circuit. By replacing R3 with a LED, buzzer or other load, a simple movement detection indicator can be constructed. Depending on the choice of the Q1 FET, higher loads can be driven (i.e. connecting power direly to a GPS receive unit, turning on a motor etc.).

TUNING

To increased time the switch-opening time constant, increase R2 or C1. If using the FET buffer typical values for R2 from are 1 M Ω to 10 M Ω . If driving a microcontroller pin directly, the practical limit for R2 might be in the 5 M Ω range depending on the input impedance of the pin. If the switch-opening time constant is not fast enough, you can lower the C2 value – but this will reduce the chatter damping. A good balance can be achieved between noise rejection and response time.

The value for C1 is not critical. Values from 0.01 uF to 0.1 uF are suitable depending on the desired time constants.

The FET example can be used for Vcc down to about 2.0 V. Typical FET turn on voltages are around 1.7 V, but at reduced voltages the time constant will increase modestly.